

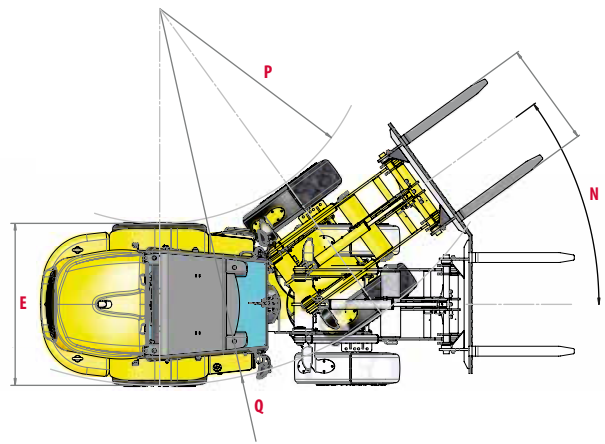

# DIMENSIONS

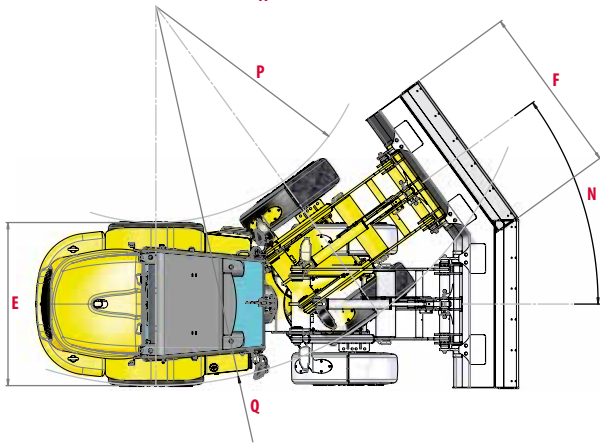
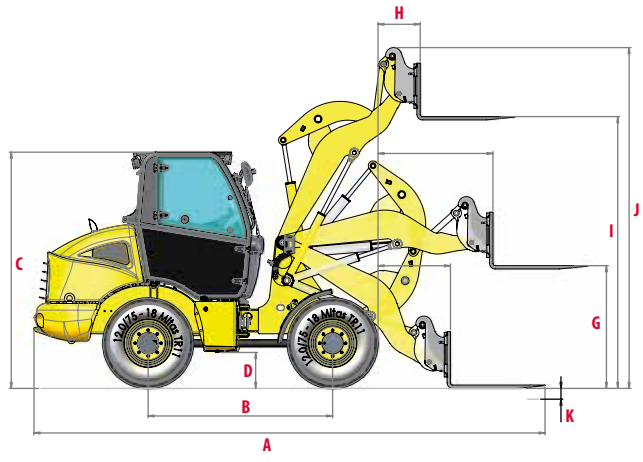
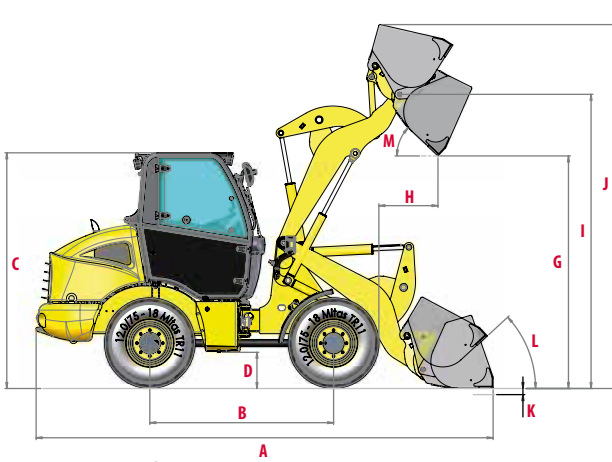

	V7	V8
<b>A</b> » Overall length	4800 mm	4800 mm
<b>B</b> » Wheelbase	1950 mm	1950 mm
<b>C</b> » Overall height (cabin/canopy)	2460 mm	2460 mm
<b>D</b> » Ground clearance	350 mm	350 mm
<b>E</b> » Overall width (outside of tires)	1620 mm	1620 mm
<b>F</b> » Overall width (bucket)	1700 mm	1900 mm
<b>G</b> » Dumping height (w/o teeth)	2450 mm	2450 mm
<b>H</b> » Dumping reach (w/o teeth)	650 mm	650 mm
<b>I</b> » Max. hinge pin height	3100 mm	3100 mm
<b>J</b> » Max. lifting height	3800 mm	3800 mm
<b>K</b> » Digging depth	65 mm	65 mm
<b>L</b> » Tilt back angle (at traveling position) Deg.	42°	42°
<b>M</b> » Dumping angle Deg.	43°	43°
<b>N</b> » Articulation angle Deg.	40°	40°
<b>P</b> » Turning radius (track circle)	3790 mm	3790 mm
<b>Q</b> » Turning radius (bucket circle)	4210 mm	4210 mm

■ Subject to technical modifications. Dimensions in mm with specific Yanmar bucket.



# SPECIFICATIONS



## WEIGHT +/- 2% (CE STANDARDS)

	V7	V8
Operating weight	4100 kg	4350 kg



## ENGINE

Type	4TNV88
Fuel	Diesel
Net Power	35 kW / 48 HP / 3000 rpm
Battery	12 V
Alternator	65 A (for the V8 version)
Engine emissions	Stage IIIA (EG 97/68)



## HYDRAULIC SYSTEM

	V7	V8
Hydrostat / 1 axial piston pump	350 bar	500 bar
3. Section / 1 gear pump	60 l/min / 200 bar	60 l/min / 230 bar



## PERFORMANCE

	V7	V8
Travel speed	7 / 20 km/h (with speed limiter)	7 / 20 km/h (with speed limiter)
Static Tipping Load Straight	3000 kg	3300 kg
Static Tipping Load Full Turn	2700 kg	3000 kg
Breakout force (bucket)	46,1 kN	52,97 kN
Traction force	2300 kg	3030 kg
Gradability	36°	
Noise level (2000/14/CE & 2005/88/CE)	LwA 101 dB / LpA 75 dB	



## CHASSIS AND TIRES

Standard tires	12.0/75 R18
----------------	-------------



## CAPACITIES

Fuel tank	60 l
Engine oil	7 l
Hydraulic tank	60 l

## MAINTENANCE FREQUENCY

Change engine sump oil: **500 hours** | Change engine oil filter: **500 hours** | Change engine fuel filter: **500 hours** |  
Change hydraulic oil: **1,000 hours** | Change cooling fluid: **1,000 hours**