



YANMAR

WHEEL LOADERS

V7 – V8



V7

Engine model	YANMAR 4TNV88
Net power	48 HP
Operating weight	4100 kg
Bucket capacity	0,7 m ³

V8

Engine model	YANMAR 4TNV88
Net power	48 HP
Operating weight	4350 kg
Bucket capacity	0,8 m ³

YANMAR WHEEL LOADER THE TOOLCARRIER



RIGID AND STRAIGHT ARTICULATION

For improved reliability, for improved stability. Front and rear wheels follow the same track. No damage of lawn and pavements. Small turning circle and optimal positioning of pallet forks. Less tire wear.



POWERFUL YANMAR ENGINE

4 cylinders, direct injection diesel engine, water cooled. Emissions in accordance with Stage IIIA. Low fuel consumption, low maintenance costs, low noise level, Easy maintenance. Engine mounted longitudinally, reduced the machine dimension.



BEST COMPONENTS

Developed in Europe with renowned components for top quality. Design and performance of the components are made for heavy-duty job sites and long service life.



OSCILLATING REAR AXLE

Improved drive comfort. Increased machine stability on all surfaces. Extended machine life. Best stability with bucket and pallet forks. This is one of the greatest strengths of Yanmar loaders.



EASE OF MAINTENANCE

Engine mounted longitudinally. Perfect access to all maintenance and service points.



FOR YOUR JOBSITE



CABIN

Quiet, comfortable and with optimal 360° view (all around visibility). Driver seat and steering column are adjustable. New concept and design of heater and air conditioning system.



EASY OPERATION, MULTIFUNCTIONAL JOYSTICK

All main functions, like driving forward/reverse, selecting driving speed, working hydraulic and differential lock on demand are centralized on the multifunctional joystick.



Z-CINEMATIC

Automatic Shovel Return, High Break Out Force and a good view to the attachments at any time.



STANDARD HYDRAULIC QUICK HITCH

Operated hydraulically, enable fast change between different attachments. Including the working hydraulic line (3rd Section) to operate several attachments that require hydraulic performance.





OPERATOR STATION

ALL-AROUND VISIBILITY

Visibility has been optimized through big windows. The optimal visibility leads to greater safety on jobsites. Front visibility is optimum on the attachment for faster and safer operation.



MULTIFUNCTION JOYSTICK

The multifunction joystick contributes to the ease of operation. It integrates forward-reverse switch, travel speed selector, differential lock 100 % on demand * and hydraulic quick coupler. A lot of attention has been paid to an outstanding ergonomomy to improve operator comfort.

* V8, not available for V7

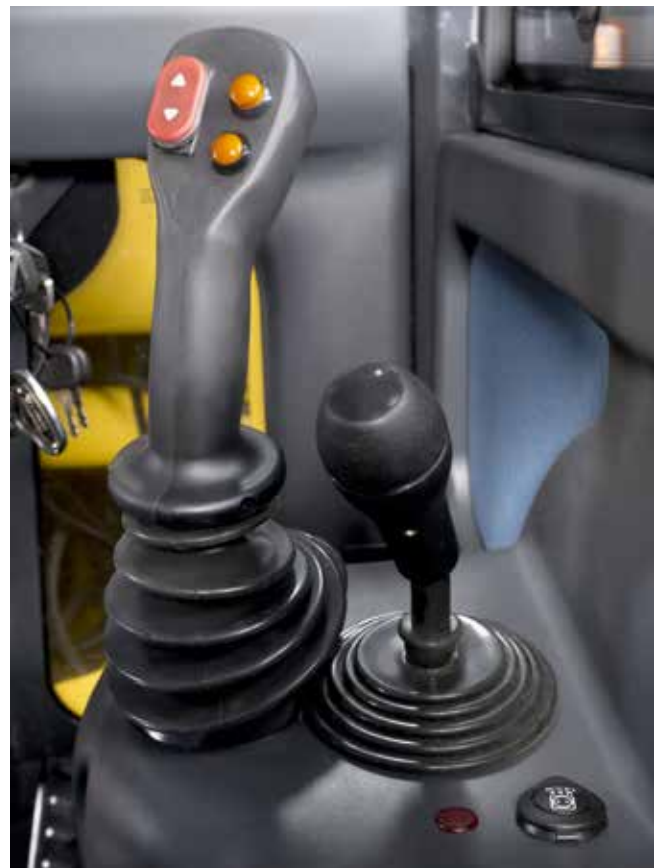

INSTRUMENTATION

The dashboard gives an easy access to the machine working information through the use of gauges and icon light. All switches are centralized for improved operation and safety.



COMFORTABLE, ADJUSTABLE SEAT

Our standard seat, adjustable in position and weight, makes it more comfortable for the driver. Our standard seat has a high back and a headrest.

ADJUSTABLE STEERING COLUMN

The adjustable steering column is part of the standard equipment of the machine. It improves the operator comfort and makes it easier to enter and exit the cabin.





POWER TRAIN

TRAVEL SPEED

The Yanmar hydrostatic transmission has two travel speeds, from 0 to 7 km/h, and from 0 to 20 km/h. As an option, the V8 can also offer 0 to 28 km/h.



BRAKE INCHING* AND SLOW MOTION DEVICE**

By using the inch brake pedal, fine-tuning of the hydraulic performance is possible.

The driver can modify the power between the drive and the working hydraulics. It allows to slowdown the loader while keeping the engine rpm up. This feature improves the cycle-time of digging and loading operations. The inch brake pedal prevents wheel spin and avoids excessive wear of the tires.

The inch brake pedal prevents wheel spin and avoids excessive wear of the tires.



* Standard on V8 / Option for V7

** Option for V7 and V8



DIFFERENTIAL LOCK ON DEMAND*

The Yanmar V8 offers 100% differential lock on demand, which is a great asset when wheels are slipping in muddy or slippery ground conditions.

TRAVEL RIDE CONTROL**

The travel ride control function induces a suspension effect in the boom cylinder thanks to an accumulator. This system improves the drivability of the loader when transporting loads on uneven ground or driving at high travel speed. This feature improves drastically the operator comfort.

TRACTIVE FORCE

The hydrostatic transmission which is perfectly matched to the performance of the Yanmar engine is characterized by its high power and smooth adjustment. This results for the operator in high rim pull for effective pushing or digging and good travel performance even on steep inclines.

* Standard on V8 / not available on V7

** Option for V7 and V8



LIFTING FRAME

Z-BAR

The Z-bar linkage offers high breakout force and fast cycle times. The linkage choice was made to improve the productivity of the Yanmar wheel loader. The wheel loaders equipped with Z-bar linkage are able to maintain high torque in a lower lift arm position, ideal for load application.



HYDRAULIC QUICK HITCH

The hydraulic quick hitch is part of the standard equipment of the Yanmar compact wheel loaders. It is easy and very safe to operate and allows quick and smooth change of attachments. Yanmar also integrated in standard the auxiliary hydraulic circuit for hydraulically driven attachments.

As an option, we have quick hitch compatible with Volvo system attachments or skid-steer loader system attachments.



SKID STEER LOADER UNIVERSAL COUPLER

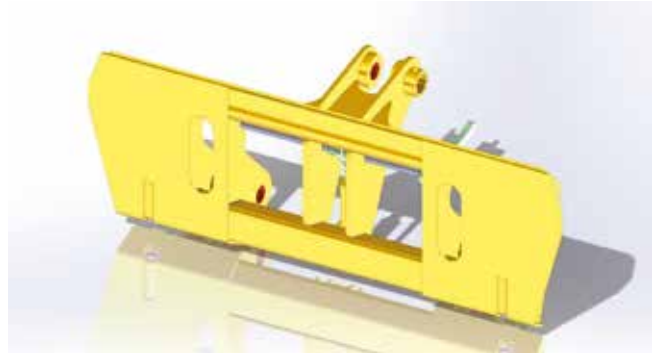

RETURN TO DIG

The V7 & V8 models are also standard equipped with a return to dig feature. When the operator lowers the loader arm, the shovel returns automatically to load position.





LOADER CONCEPT

ARTICULATION CONCEPT

Yanmar decided to use a concept with straight articulation joint with a rear oscillating axle for its wheel loaders. This concept derives from big wheel loaders and is chosen for its simplicity and robustness. It also presents following features:

- Operator stays in the same inclination than the bucket on uneven ground, providing more precision especially in pallet forks application.
- Improved lifting capacity with front frame in articulated position, since the rear part acts as a counterweight.
- More pressure on the bucket during backfilling, making levelling operations easier and faster.

DIMENSIONS

The V7 & V8 have very compact dimensions in all aspects: height (< 2,5m), width, length and turning radius. These compact dimensions contribute to the high maneuverability of Yanmar wheel loaders.





ENGINE

Yanmar equips the V7 & V8 with the Yanmar 4TNV88 engine. TNV stands for Total New Value. This engine integrates a new design of the combustion chamber to achieve cleaner burn and lower exhaust emissions. The design integrates also an improved and optimized stiffness in order to reduce significantly the vibrations and the noise level. The improved block cooling of the TNV engine range enhances the durability and service life of this main component.

The conception of the engine compartment is inherited from the design of heavy wheel loaders, where the engine is mounted in line. This design offers the advantages of 100 % accessibility to service components and better cooling performance for a longer service life.



HYDRAULICS

HYDROSTATIC TRANSMISSION

Hydrostatic high pressure transmission, with automatic power regulation and closed circuit with variable-displacement pump and variable displacement motor (HA Automatic SHIFT).

HA AUTOMATIC SHIFT

The HA automatic control high-pressure shift changes automatically the travel speed according to the required performance. The automatic travel speed change is easy to use for the operator, improves his comfort, and chooses always the optimal combination between torque and speed.

Handheld hydraulic breaker kit is foreseen as an option. Yanmar does also offer a high flow kit to drive more demanding attachments like blowers, movers, etc.

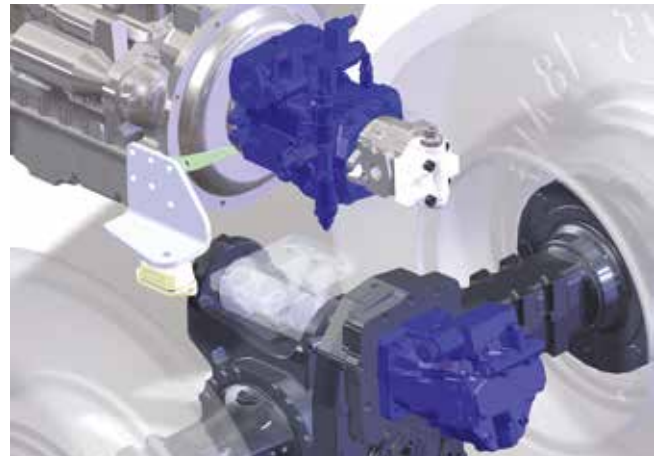



MAINTENANCE

The large opening offered by the engine hood allows an easy access to all main service items, for an easy and fast maintenance. This contributes to reduce the TCO of the machine.



RELIABILITY

LONG SERVICE INTERVALS

Our compact wheel loaders are designed for working, and therefore we reduced the service intervals to a minimum. Engine- and Hydraulic Oil interval start respectively at 500 and 1000 working hours and greasing intervals are every 50 hours.



BEST COMPONENTS

The Yanmar compact wheel loaders are developed in Europe, and use only premium components. Quality and reliability are the main drivers of our product development.



Z-BAR LINKAGE

Z-bar linkage has the least number of pins, links and levers to maintain.



EQUIPMENT

STANDARD EQUIPMENT

ENGINE

- 4TNV88 Yanmar diesel
- Battery main switch

HYDRAULIC SYSTEM

- 3rd control section (front hydraulic kit)

CABIN

- Door on the left handside
- Hydraulic quick coupler
- Central dashboard
- Radio preparation without radio, speaker and antenna
- Forward/reverse switch control on single lever joystick
- Front windscreen ventilation
- Heating system with heat exchange and 3-stage fan
- ROPS / FOPS cab with opening window on the right hand side

- Windscreen wipe and wash unit in front and rear

CHASSIS AND TIRES

- Heavy duty axles
- Tires: 12.0/75 R18
- Z-bar linkage
- Central articulation and oscillating rear axle
- Service brake drum-type on the front axle working on all 4 wheels
- Parking brake drum-type working on front axle
- Hydrostatic transmission: 2 forward/reverse speed (max. 20km/h)
- Counterweight 250 kg (only for the V8 version)

SAFETY

- Steering System - servo controlled by priority valve « LOADSENSING » system
- Driver seat with safety belts
- Rear view mirrors, foldable
- Back-up alarm
- Proportional self-lock front differential
- Inch brake pedal

LIGHTING

- Working lights front and rear
- Warning beacon standard with magnetic holder

MISCELLANEOUS

- CE quality inspection

OPTIONAL EQUIPMENT

ENGINE

- Power battery (up to 80A)
- High speed mode with max. 28km/h (only for the V8 version)
- Manual throttle (engine rpm) (only for the V8 version)

HYDRAULIC SYSTEM

- High flow kit with 84 l/min 230 bars (incl. Add. Oil cooler)
- Hydraulic kit for hand operating breaker (without breaker)
- Double front hydraulic (4th section)

CABIN

- Radio player
- Air conditioning
- Speed reduction kit
- Safety air filter (active coal) in the cabin

- Vortex prefilter (cyclon dust separator)

CHASSIS AND TIRES

- Tires 12.0/75/18 – 12 pr MITAS
- Tires 340/80R18 Michelin XMCL Agri-Profil
- Low compaction tires 12.5/80-18 -14 pr – MITAS
- Nokian Winter Tires (only for the V8 version)

SAFETY

- Proportional self-lock rear differential
- Bucket cylinder safety block valve
- Loader arm cylinder safety block valves
- Descent regulation valve
- Inch brake pedal for V7

- Travel ride control
- Heatable mirror

COUPLERS

- Quick coupler system for Volvo front attachment
- Quick coupler system for Skidsteer front attachment
- Universal adapting plate for front attachment

MISCELLANEOUS

- Front electric kit
- Agricultural version (sucting fan + fine-mashed net grill)
- Central lubrication unit (only during assembling –no kit)
- Special paint
- Bio oil



ATTACHMENTS

Yanmar gives you the accessories that fit your needs and match the safety standards in force in your country: standard bucket, 4 in 1 bucket, light material bucket, side dumping bucket with teeth, pallet forks with teeth, frontend road sweeper with harvest bucket + side brush + water reservoir



DIMENSIONS

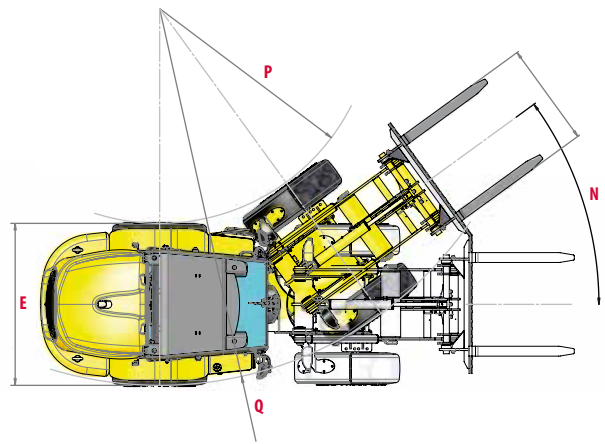
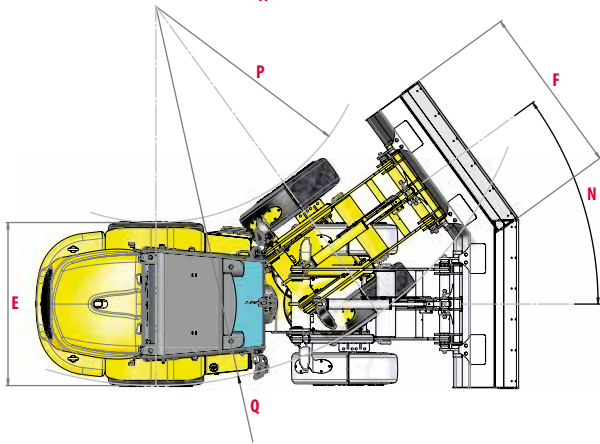
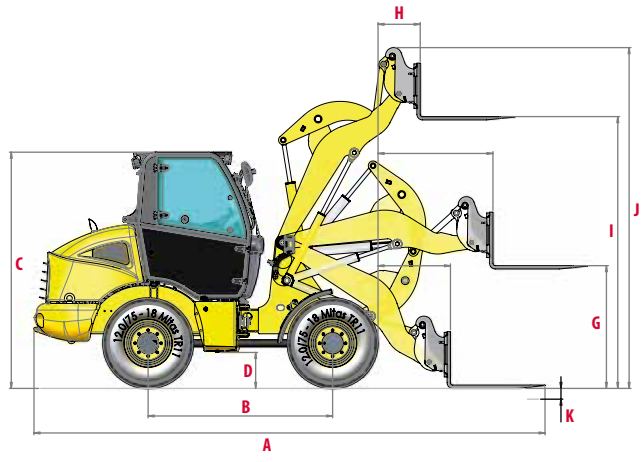
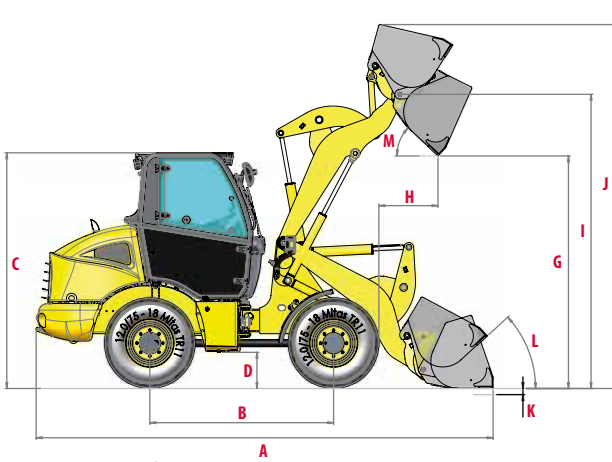

	V7	V8
A » Overall length	4800 mm	4800 mm
B » Wheelbase	1950 mm	1950 mm
C » Overall height (cabin/canopy)	2460 mm	2460 mm
D » Ground clearance	350 mm	350 mm
E » Overall width (outside of tires)	1620 mm	1620 mm
F » Overall width (bucket)	1700 mm	1900 mm
G » Dumping height (w/o teeth)	2450 mm	2450 mm
H » Dumping reach (w/o teeth)	650 mm	650 mm
I » Max. hinge pin height	3100 mm	3100 mm
J » Max. lifting height	3800 mm	3800 mm
K » Digging depth	65 mm	65 mm
L » Tilt back angle (at traveling position) Deg.	42°	42°
M » Dumping angle Deg.	43°	43°
N » Articulation angle Deg.	40°	40°
P » Turning radius (track circle)	3790 mm	3790 mm
Q » Turning radius (bucket circle)	4210 mm	4210 mm

■ Subject to technical modifications. Dimensions in mm with specific Yanmar bucket.



SPECIFICATIONS



WEIGHT +/- 2% (CE STANDARDS)

	V7	V8
Operating weight	4100 kg	4350 kg



ENGINE

Type	4TNV88
Fuel	Diesel
Net Power	35 kW / 48 HP / 3000 rpm
Battery	12 V
Alternator	65 A (for the V8 version)
Engine emissions	Stage IIIA (EG 97/68)



HYDRAULIC SYSTEM

	V7	V8
Hydrostat / 1 axial piston pump	350 bar	500 bar
3. Section / 1 gear pump	60 l/min / 200 bar	60 l/min / 230 bar



PERFORMANCE

	V7	V8
Travel speed	7 / 20 km/h (with speed limiter)	7 / 20 km/h (with speed limiter)
Static Tipping Load Straight	3000 kg	3300 kg
Static Tipping Load Full Turn	2700 kg	3000 kg
Breakout force (bucket)	46,1 kN	52,97 kN
Traction force	2300 kg	3030 kg
Gradability	36°	
Noise level (2000/14/CE & 2005/88/CE)	LwA 101 dB / LpA 75 dB	



CHASSIS AND TIRES

Standard tires	12.0/75 R18
----------------	-------------



CAPACITIES

Fuel tank	60 l
Engine oil	7 l
Hydraulic tank	60 l

MAINTENANCE FREQUENCY

Change engine sump oil: **500 hours** | Change engine oil filter: **500 hours** | Change engine fuel filter: **500 hours** |
Change hydraulic oil: **1,000 hours** | Change cooling fluid: **1,000 hours**



YANMAR



Printed in France – Materials and specifications are subject to change from the manufacturer without notice – Please contact your local Yanmar Construction Equipment Europe dealer for further information.

Yanmar Construction Equipment Europe S.A.S.

25, rue de la Tambourine
52100 SAINT DIZIER – FRANCE
contact@yanmar.fr

www.yanmarconstruction.eu