

DIMENSIONS

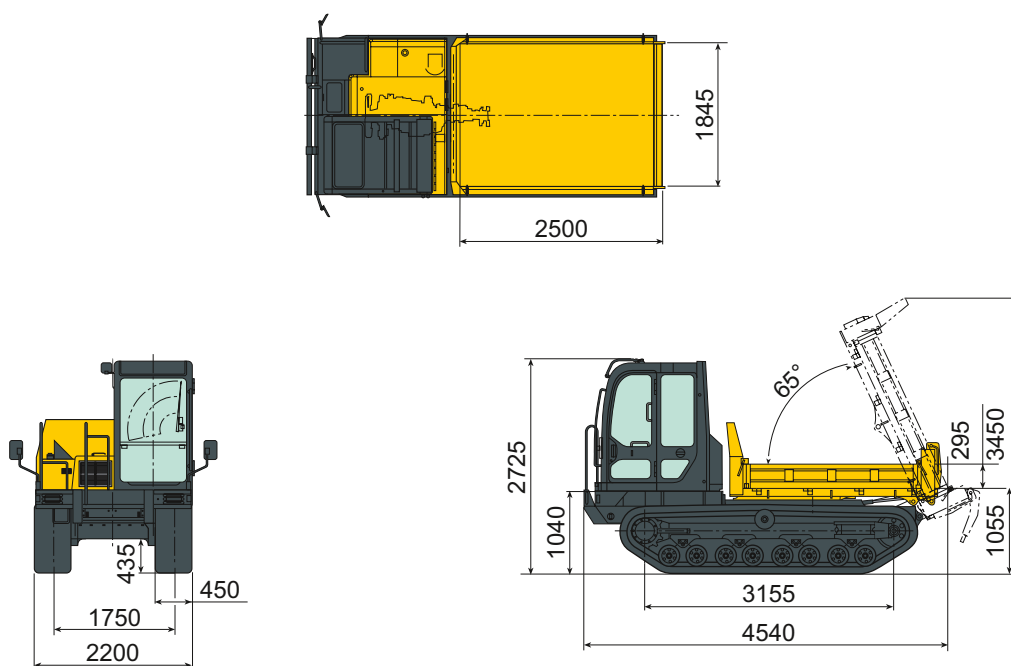

C50R-5A



C50R-5ATV

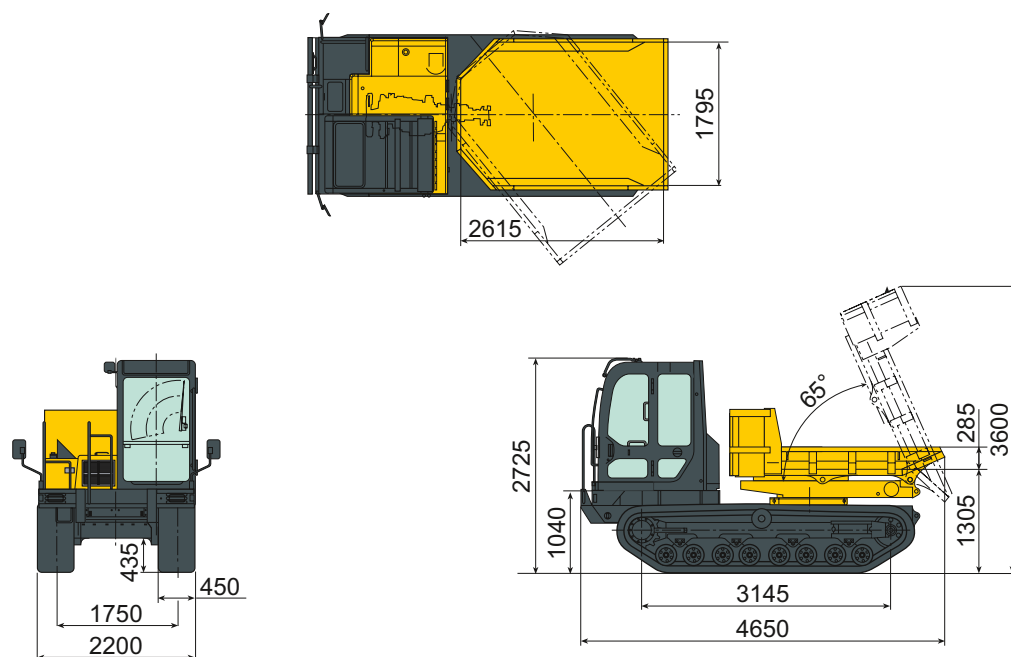

SPECIFICATIONS

[WEIGHT +/- 2% (EN STANDARDS)]

	C50R-5A	C50R-5ATV
Operating weight	6015 kg	6345 kg
Transport weight	5940 kg	6270 kg
Payload	3800 kg	3500 kg
Operating weight with load	9815 kg	9845 kg

[ENGINE]

	C50R-5A	C50R-5ATV
Type	Direct injection, water cooled, diesel 4TNV94FHT	Direct injection, water cooled, diesel 4TNV94FHT
Net power	83,2 kW (at 2500 rpm)	83,2 kW (at 2500 rpm)
Displacement	3,053 l	3,053 l
Maximum torque at 1700 rpm	378-410 N.m	378-410 N.m

[PERFORMANCE]

	C50R-5A	C50R-5ATV
Dumping angle	65 °	65 °
Vessel dimensions (L x w x h)	2 500 x 1 844 x 294 mm	2 616 x 1 794 x 285 mm
Dumping mechanism	1 side (rear)	3 sides
Dump vessel capacity (struck / heaped)	1,4 / 2,3 m ³	1,2 / 2,1 m ³
Dump clearance	658 mm	891 mm
Max. travelling speed (low / high)	7,0 km/h	9,5 km/h

[UNDERCARRIAGE]

	C50R-5A	C50R-5ATV
Track width	450 mm	450 mm
Min. ground clearance	433,5 mm	433,5 mm
Ground pressure (unloaded / loaded)	19,8 / 33 kPa	20,9 / 33,1 kPa

[MISCELLANEOUS]

C50R-5A	C50R-5A	C50R-5ATV
Hydraulic circuit (total)	75 l	75 l
Hydraulic tank	44 l	44 l
Fuel tank	121,1 l	121,1 l
Noise Level Lwa	102 dBA	102 dBA