

TECHNICAL SPECIFICATIONS

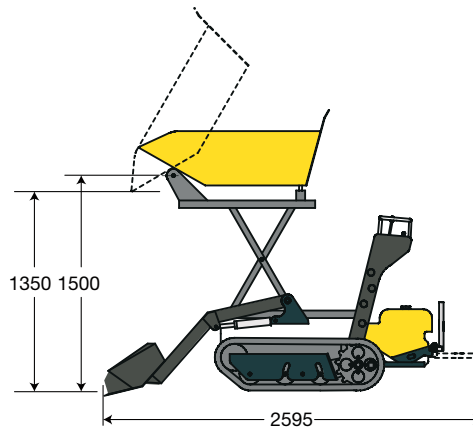
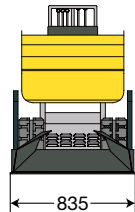
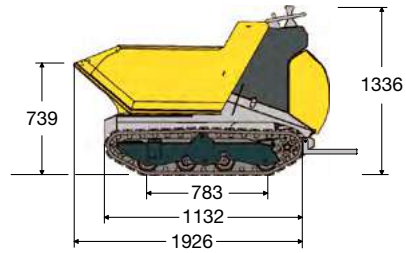
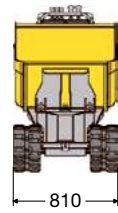

[WEIGHT]

	POWER	POWER+	HI TIP	HI TIP+
Operating weight	570 kg	660 kg	670 kg	765 kg

[ENGINE]

Type	LV 100
Fuel	Diesel
Net power	8.7 HP

[HYDRAULIC SYSTEM]

Transmission	Hydrostatic
Hydraulic pumps	2 pumps with variable flow for the translation 1 pump with fix flow for the equipment

[PERFORMANCE]

Max. travelling speed	4 km/h
Payload	800 kg
Dump vessel capacity SAE (POWER)	0,45 m ³
Dump vessel capacity SAE (POWER+)	0,36 m ³
Dump vessel capacity SAE (HI TIP)	0,36 m ³
Dump vessel capacity SAE (HI TIP+)	0,36 m ³

[UNDERCARRIAGE]

Track width	180 mm
Type	Track rollers